

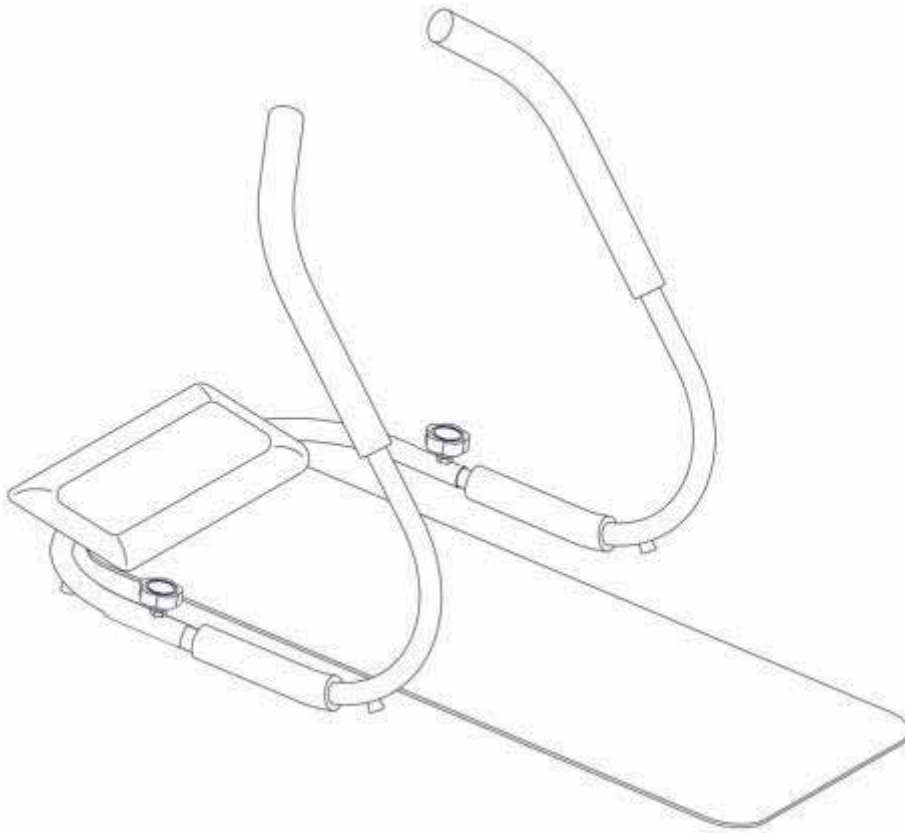

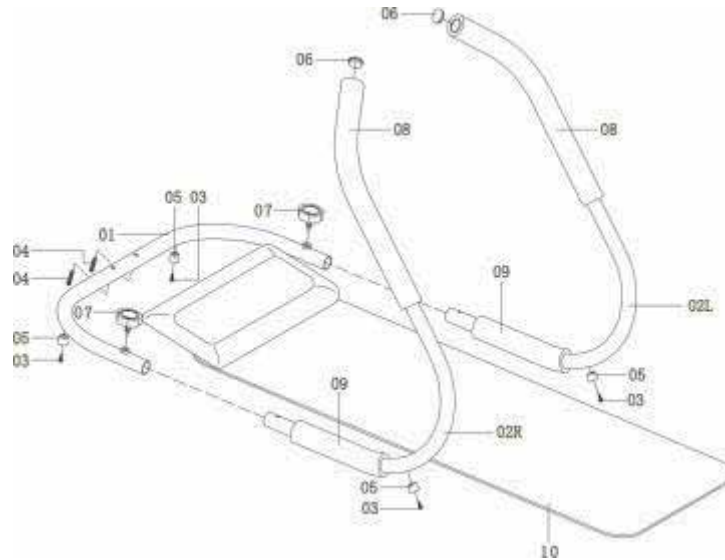





AB ROLLER ASSEMBLY INSTRUCTION



Exploded Drawing



Part No	Description	Pic. for Ref.	Q'ty
01	Bottom Rod		1
02 L&R	Handlebar L&R		2
03	Screw		4
04	Screw		2
05	Buffer Ring		4
06	Cap		2
07	Knob		2
10	Mat		1

Assembly Instruction

Step 1

Lay the bottom rod (01) parallel. Insert handlebar (02L) into bottom rod(01),then screw the knob (07) into the corresponding holes on bottom rod (01) and handlebar (02L).

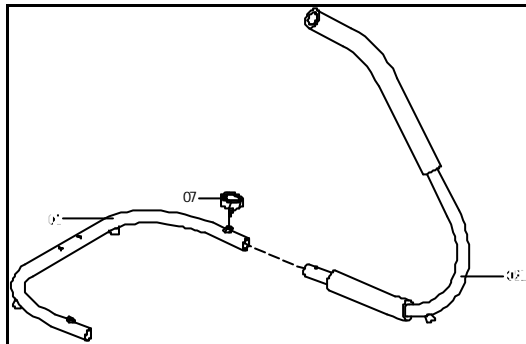

Step 2

Insert handlebar (02R) into bottom rod (01),then screw the knob (07) into the corresponding holes on bottom rod (01) and handlebar (02R).

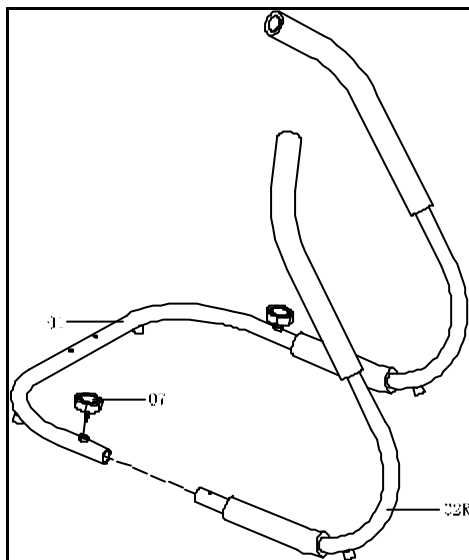

Step 3

Place the mat (10) between the bottom rod (01). Fix the two parts together with screws (04).

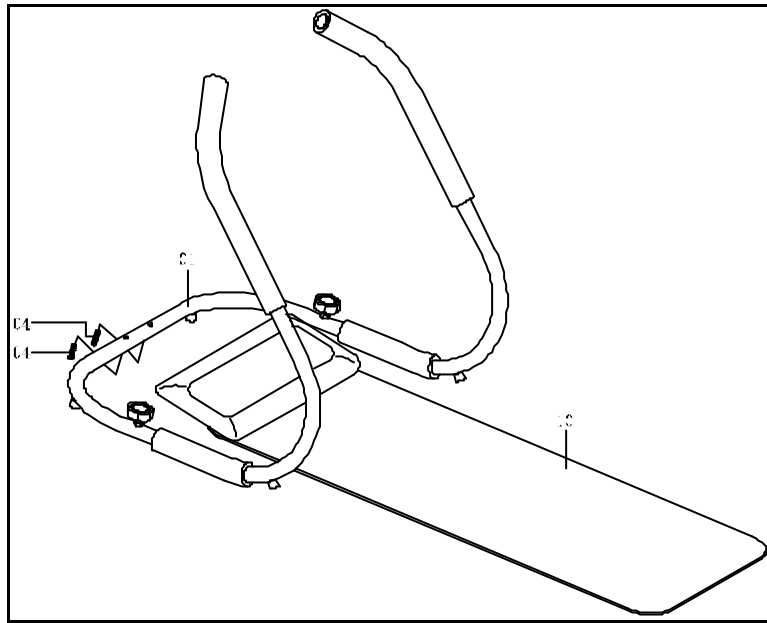

NOW YOUR MACHINE HAS BEEN WELL ASSEMBLED.

AB ROLLER AUFBAUANLEITUNG

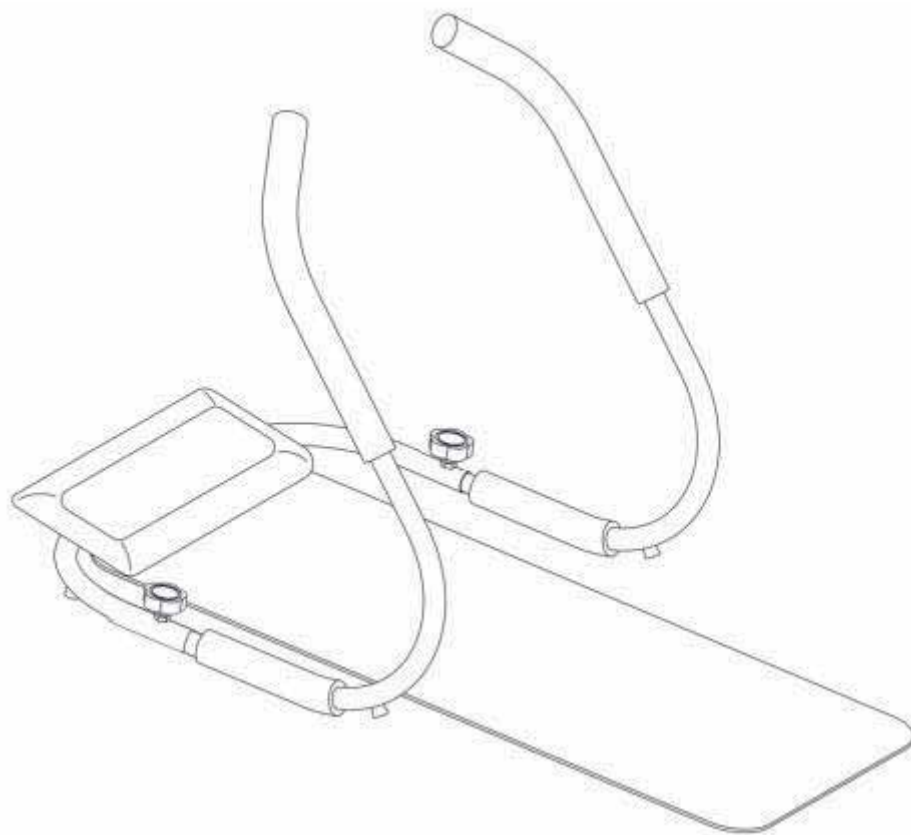

EXPLOSIONSZEICHNUNG

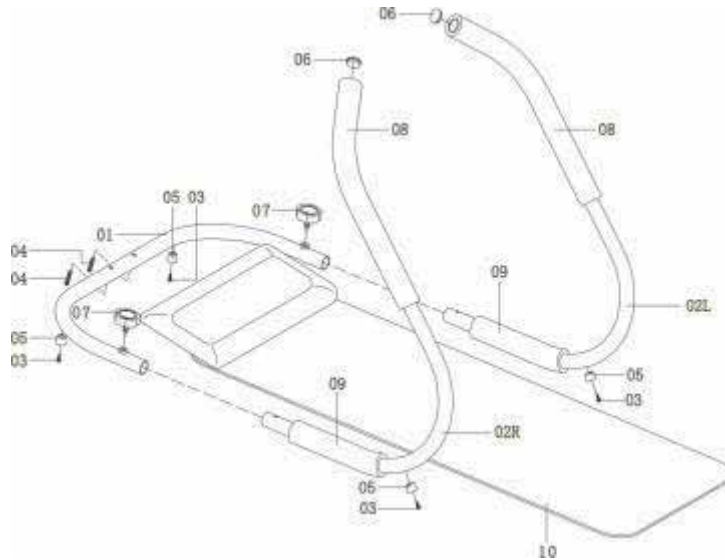

Teile-Nr.	Beschreibung	Bild	Anzahl
01	Bodenstange		1
02 L&R	Griffstange L&R		2
03	Schraube		4
04	Schraube		2
05	Ringspeicher		4
06	Abdeckkappe		2
07	Handgriff		2
10	Matte		1

Aufbauanleitung

Schritt 1

Legen Sie die Bodenstange auf den Boden (01). Schieben Sie die Griffstange (02L) in die Bodenstange (01), und schrauben mit dem Handgriff (07) in das vorgesehene Loch in der Bodenstange (01) und Griffstange (02L).

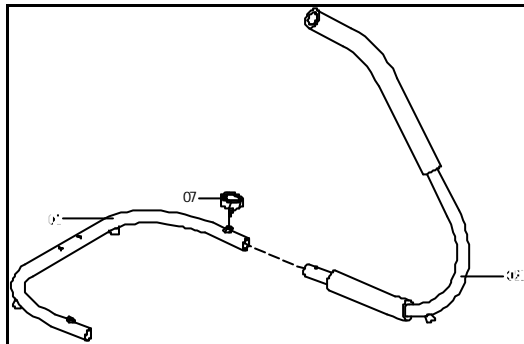

Schritt 2

Schieben Sie die Griffstange (02R) in die Bodenstange (01), und schrauben mit dem Handgriff (07) in das vorgesehene Loch in der Bodenstange (01) und Griffstange (02R).

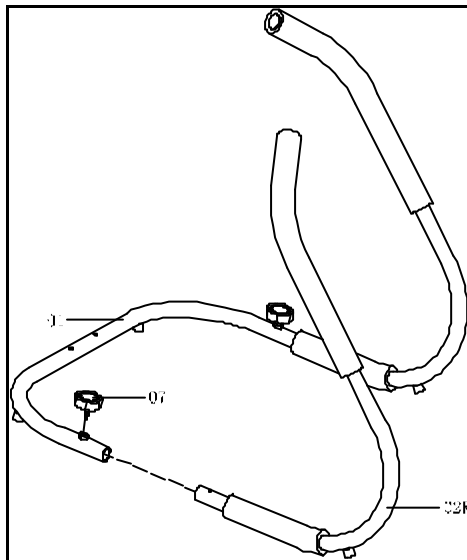

Schritt 3

Fixieren Sie die Bodenmatte (10) zwischen der Bodenstange (01).
Befestigen Sie beide Teile mit Schrauben (04).

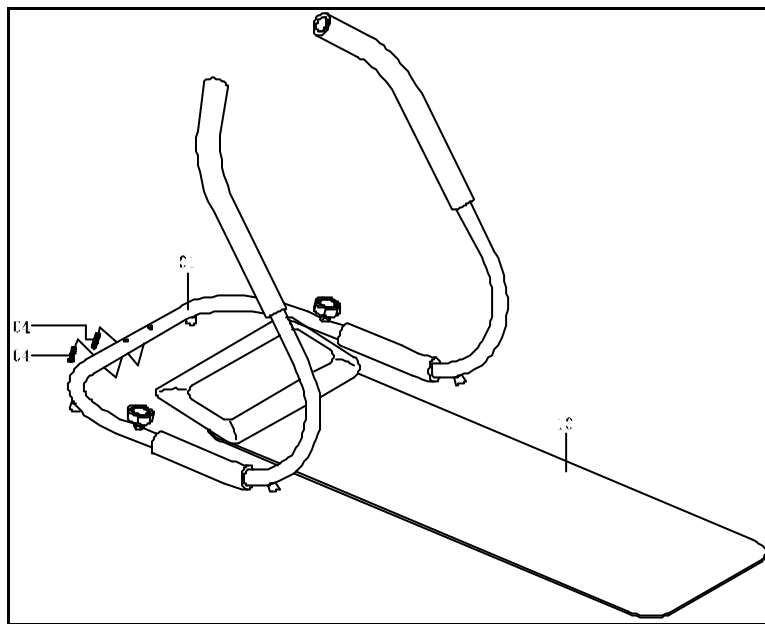

JETZT IST IHR GERÄT KOMPLETT ZUSAMMENGEBAUT.